



INSTALLATION INSTRUCTIONS

TD-8 SERIES

DIGITAL-SET SINGLE-FUNCTION TIME DELAY RELAY

December 2020, Rev C

901-0000-277

**READ INSTRUCTIONS BEFORE INSTALLING OR OPERATING THIS DEVICE.
KEEP FOR FUTURE REFERENCE.**

Installation: Mount the appropriate octal socket (see below) in a suitable enclosure. Use one or two #12-22 solid or stranded wire with Macromatic sockets, with a recommended terminal tightening torque of 6-7 in-lbs (maximum of 12 in-lbs). Set the time delay as described below. Wire the socket per the appropriate diagram below or use the one on the side of the product. Plug product into socket.

Function	Number of Pins	Macromatic Socket	Wiring Diagram
TD-802 TD-805 TD-831 TD-851 TD-861	8	70169-D	
TD-815 TD-816	11	70170-D	

Programming Time Delay:

Programming is accomplished through the use of a 10-position DIP-switch (two on Repeat Cycle functions). Each position is marked with a binary time increment. The required delay is selected by moving the switch of each increment to the ON position & adding their corresponding values (see right).

LED Indicator: Red ON Steady--Relay Energized; OFF--Relay De-Energized

Troubleshooting: If the product fails to operate properly, check that all connections are correct per the diagram on the side of the product. Use the descriptions of how each function operates below as a guide to determine if the product is operating properly. If problems continue, contact Macromatic at 800-238-7474 for assistance.

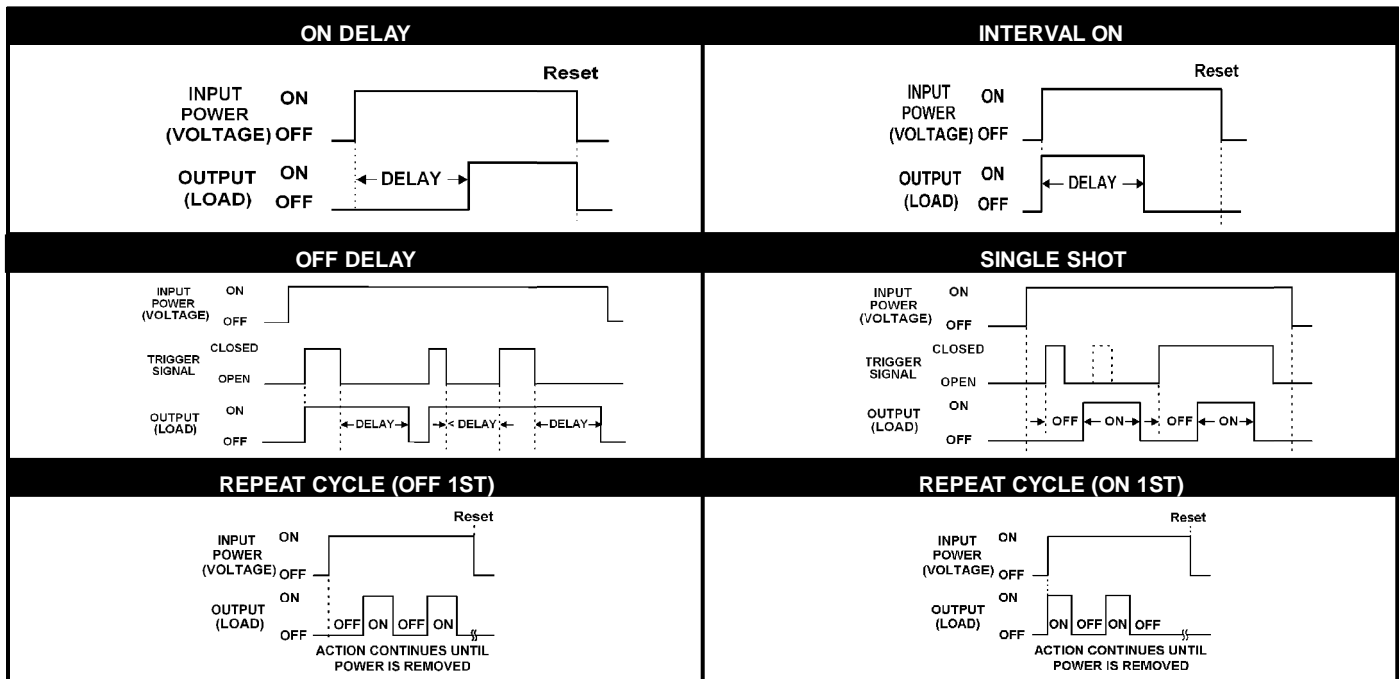
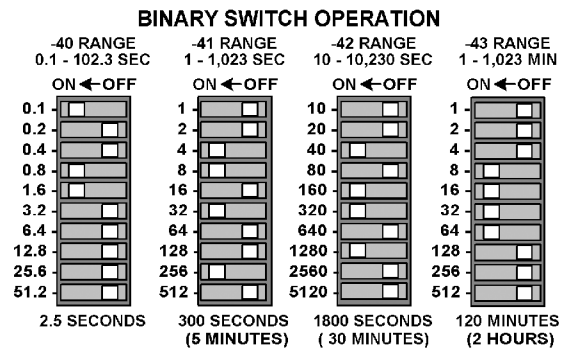

Warranty

All products manufactured by Macromatic are warranted to be free from defects in workmanship or material under normal service and use for a period of five (5) years from date of manufacture.