



Installation Instructions

VxE Series Voltage Monitor Relays

March 2025

901-0000-367

Potentially hazardous voltages are present. Electrical shock can cause death or serious injury. Installation should be done by qualified personnel following all National, State & Local Codes.

Présence de tensions potentiellement dangereuses. Une décharge électrique peut causer la mort ou des blessures graves. L'installation devrait être effectuée par du personnel qualifié suivant tous les codes nationaux, provinciaux et locaux.

BE SURE TO REMOVE ALL POWER SUPPLYING THIS EQUIPMENT BEFORE CONNECTING OR DISCONNECTING WIRING. READ INSTRUCTIONS BEFORE INSTALLING OR OPERATING THIS DEVICE. KEEP FOR FUTURE REFERENCE.

Installation & Wiring

- Mount the VxE product on 35mm DIN Rail. Hook the fixed (upper) DIN clip over the top edge of the DIN rail and rotate the product downward applying pressure to snap the lower DIN clip over the rail edge, securing the product to the rail.
- VxE Series products can be mounted immediately next to other DIN rail devices or independently, separated from nearby DIN rail devices as desired. If mounting immediately next to other devices, please review the Installation Considerations.
- Wire the product as appropriate for your installation, using the wiring diagram on the side of the product and the application diagram below. Use 14-22AWG solid or stranded copper wire with a terminal tightening torque of 4 in-lbs (0.45 N-m).

Setting the VxE

- Adjustable voltage VxE products have 3 blue dials on the front face (4 dials for multifunction units). Rotate each dial's pointer to the desired setting. For assistance on setting the dials, see the "Product Operation" section on the back. A 1/8" (3mm) flat-blade (slotted) or Philips screwdriver is recommended. The voltage range is printed on the side of the nameplate for reference. Please note that the dial markings are for reference only and may not be exact.

Installation Considerations:

- When installing VxE series products immediately next to other DIN rail devices, heat from the surrounding devices should be considered. Derating and/or spacing may be needed. Although each installation is unique, manufacturer recommendations and derating tables are provided below for guidance

Suggested Derating Factor for Contact Ratings

Surrounding Air Temperature	25C	40C	50C	55C	60C	65C
0MM Spacing	None	None	None	.8	.3	-
5MM Spacing	None	None	None	None	None	None

Notes:

- Spacing is the distance between the VxE series product and the next closest DIN rail devices on the same DIN rail.
- The surrounding air temperature is the highest air temperature immediately surrounding the device.
- These spacing and derating factors were developed under worst case scenarios (maximum voltage, current, temperature simultaneously) and may not be required in all applications. The product is not recommended for operation under the conditions marked with "-".

WIRING DIAGRAMS

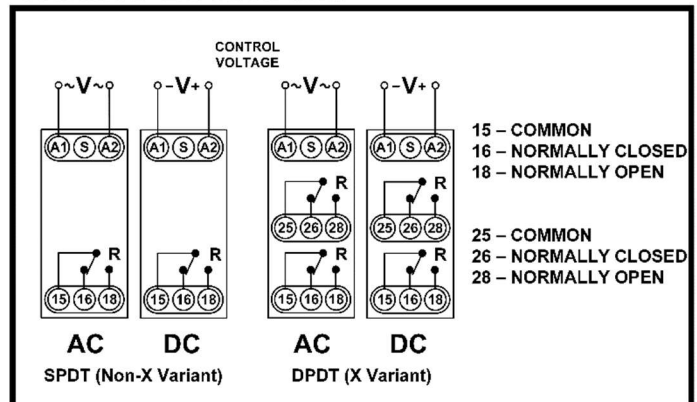

Troubleshooting

- If the unit fails to operate as expected, check that all connections are correct per the connection diagram on the product. For DC monitored voltages, make sure the polarity matches the connection diagram, with positive voltage connected to terminal A2. If problems continue, visit our website at <https://www.macromatic.com/contact-us/> to request support.

Product Operation

Find the catalog number in the table below and follow the instructions to setup the unit.

Catalog Number	Operation	Function Chart
VAE012D(X) VAE024D(X) VAE048D(X) VAE110D(X) VAE120A(X)	Adjust the pick-up voltage setting (V_{max}) between the full range as shown on the product nameplate. Then adjust the drop-out voltage setting (V_{min}) between 75% and 95% of the pickup-setting. When the monitored voltage is applied, the Green LED will illuminate. The relay energizes (and the Red LED is on) when the monitored voltage is above the pick-up setting for a period longer than the fixed pic-up time delay of 0.5 seconds. The relay de-energizes (and the Red LED is off) when the monitored voltage is below the drop-out setting for a period longer than the drop-out time delay (t), which is adjustable between 0.1-10 seconds.	<p>The chart shows a sinusoidal voltage waveform. Two horizontal lines represent the pick-up voltage (V_{max}) and drop-out voltage (V_{min}). The relay output (black bar) and LED GREEN (grey bar) are active when the voltage is above V_{max} for a duration longer than the pick-up time delay. The relay output and LED RED (grey bar) are active when the voltage is below V_{min} for a duration longer than the drop-out time delay (t).</p>
VWE012D(X) VWE024D(X) VWE048D(X) VWE110D(X) VWE120A(X)	Adjust the over voltage setting (V_{max}) between the full range as shown on the product nameplate. Adjust the under voltage setting (V_{min}) between 75% and 95% of the over voltage setting. When the monitored voltage is applied, the Green LED will illuminate. The relay energizes (and the Red LED is on) when the monitored voltage is between the over and under voltage settings. The relay de-energizes (and the Red LED is off) when the monitored voltage rises above or falls below the over or under voltage settings for a period longer than the drop-out time delay (t), which is adjustable between 0.1-10 seconds. The relay will re-energize once the monitored voltage rises above or falls below the hysteresis level of either V_{max} or V_{min} settings for a period longer than the pick-up time delay, which is fixed at 0.5 seconds.	<p>The chart shows a sinusoidal voltage waveform. Two horizontal lines represent the over-voltage setting (V_{max}) and under-voltage setting (V_{min}). Hysteresis levels are indicated by arrows between the settings. The relay output (black bar) and LED GREEN (grey bar) are active when the voltage is between V_{min} and V_{max} for a duration longer than the drop-out time delay (t). The LED RED (grey bar) is active when the voltage is above V_{max} or below V_{min} for a duration longer than the pick-up time delay.</p>

Specifications:

OUTPUT CHARACTERISTICS	
Number and type of contacts	SPDT or DPDT
Contact Material	AgSnO ₂ In
Contact Ratings	10A @250VAC, 8A @ 30VDC
Green LED Output	Illuminated: Monitored Voltage Present
Red LED Output	Illuminated: Fault Occurred (Relay de-energized) Not Illuminated: No Fault (Relay energized)

INPUT CHARACTERISTICS	
Control Voltage range (V_{max})	90-150VAC 50/60Hz; 9-15VDC, 18-30VDC, 36-60VDC, 82.5-137.5VDC
Maximum Consumption	5VA
Sensing Accuracy	Constant Conditions within Spec: +/-2%, Variable Conditions: +/-5%

TIMING CHARACTERISTICS	
Reset Time	Automatic
Pick-up Time	0.5 Seconds
Drop-out Time	0.1 – 10 Seconds
Setting Accuracy	Maximum setting: -0%/+5% , Minimum Setting: -50%/+0%

WARRANTY:

All catalog-listed products manufactured by Macromatic are warranted to be free from defects in workmanship or material under normal service and use for a period of five (5) years from the date of manufacture.